

THE RAVE STAIR LIFT

rave

AmeriGlide



Folded stair lift

Ultra-Thin Design
Great for narrow cases

Heavy Duty
Supports up to 350 lbs.

Easy to Install
Save on Installation Fees



THE RAVE STAIR LIFT



Wireless Convenience

- Wireless remote makes for ultimate convenience, a Harmar exclusive

Information At A Glance

- Easy operating controls and indicator lights

Safety And Security

- Removable key lock, for safety when you are away (opt. upgrade)

Unique Patented Drive System

- Requires less energy so it can make more than 2X's the amount of trips on battery power than other leading units

Maximum weight capacity	350 lb.
Electrical requirements	115 VAC
Operation power	24V DC Battery
Maximum travel	70 ft
Speed	17 ft/min.
Incline Limits	32 – 52 degrees
Drive system	Polymer worm/worm-rack
Motor output speed at rated load	62 rpm
Motor output torque at rated load	18 lb ft
Motor output amps at rated load	14 Amps
Track (rail) type	Extruded aluminum
Average return trips per charge (varies with load, length)	20 – 40
Tools required to install	5
Symmetrical lift (left or right stair)	Yes
Interchangeable arms (left or right hand operation)	Yes
Need to open chassis to install or change sides?	No

- Standard unit is 12ft, additional lengths available up to 70ft
- Easily changeable from left to right side
- Patented helical worm drive
- No greases or lubricants; easy to vacuum and keep clean
- Made in the USA!
- Aesthetically pleasing appearance and robust construction
- Narrowest stairlift in the industry – only 11" folded
- Comfortable seat with height adjustment
- Swivel seat at upper landing, for easy and safe entry and exit
- Safety sensors that stop the lift when it meets with an obstruction
- 90 Day warranty on parts

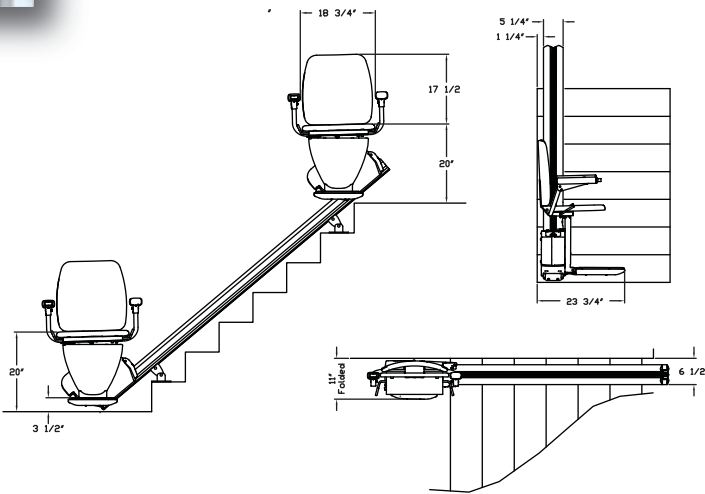

AmeriGlide Stairway Lifts and Vertical Platform Lifts are designed to meet ANSI/ASME A18.1 Performance Safety Standards when properly equipped. While AmeriGlide Stairway Lifts and VPLs meet National standards it is imperative to check State and Local code requirements before installing to ensure compliance. All local and State compliance is the responsibility of the purchaser.